



Measuring



Positioning

IKS11 Incremental Magnetic Sensing Head

- Linear Applications
- Rotational Applications
- Non contact, quick position measurement

Features

- High accuracy
- Resolution options available
- Single piece unit
- Customizable max output frequencies
- Software programmable interface
- Connector options with multiple cable lengths
- No wear from usage
- Resistant to dust, cooling lubricant emulsion, oil, etc.
- High fly height tolerance (Up to half of pole pitch)
- Unlimited measuring length



Superb performance in less space – the IKS11

With the compact incremental magnetic sensing head IKS11 BOGEN offers superb performance in a small form factor. If space is decisive the IKS11 allows easy usage. The IKS11 impresses customers in automation, instrumentation and motion control applications. In combination with BOGEN precision scales, measurement solutions for almost every application can be custom-tailored.

Features

Resolution	0.020 to 500µm, depending on the pole pitch
Energy Consumption (without Load)	<65 mA (UB = 5 V)
Operating Temperature	-20 to +70 °C
Storage Temperature	-20 to +80 °C
Protection Class	IP67
Adjustable Parameters	Resolution, maximum output frequency and interface

Resolution and Max. Speed

Output Frequency F = 1000 kHz

Pole Pitch P [mm]	Resolution R [µm]	Speed [m/s]
0.5	0.25	1
1	0.5	2
2	1	4

See chart below for other selectable output frequencies

Sensing Head Variants

Pole pitch	0.5 mm; 1 mm; 2 mm
Reference	Reference chip for 2nd track not for 0.5 mm or periodically from the pole pitch
Supply Voltage	5 V ± 5 %
Interface (without load)	D1 = RS422 (0 to 5 V) D3 = Push-Pull TTL (0 to 5 V)
Cable Length of Sensing Head	Standard length X m

Output Circuit

RS422

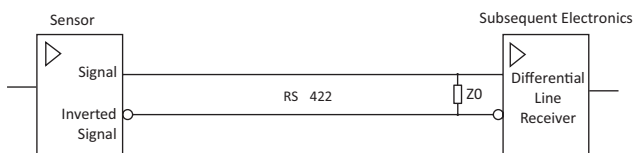

Load resistor Z0 = 120 Ω at the receiving end

Push-Pull (HTL, TTL)

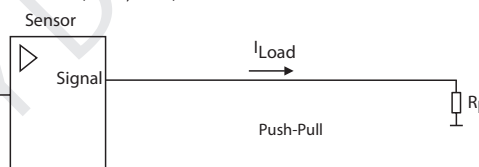

maximum of 50 mA per channel at a supply voltage of 5 V

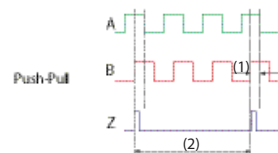
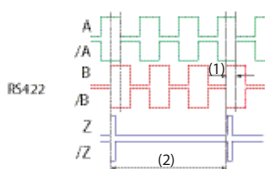

Output Signals

Signals	A, /A, B, /B, Z, /Z
Signal Error Indicator	High impedance on all output signals (A, /A, B, /B, Z, /Z)

- (1) Phase shift A and B 90° ±10° electrical
- (2) Signal period depending on the reference track pattern or as a periodic reference depending on the pole pitch
- Z Length default is 50 counts

Installation Tolerances

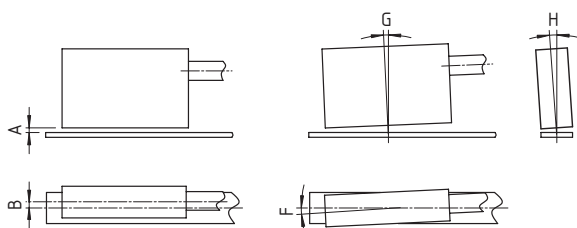

	Pole Pitch 0.5 mm	Pole Pitch 1 mm	Pole Pitch 2 mm
A [mm]	0.1 to 0.25	0.1 to 0.5	0.1 to 1.0
B ⁽³⁾ [mm]	2.5	2.5	2.5
B ⁽⁴⁾ [mm]	0.5	0.5	0.5
G	0.5°	1°	1°
H	3°	3°	3°
F	3°	3°	3°

⁽³⁾ relative to 10 mm scale width (1-track)

⁽⁴⁾ relative to 10 mm scale width (2-track)

To avoid EMI please connect housing to protective earthing!

Further Selection (Ordering Parameters)

Pole Pitch P [mm]			Resolution R [μm]	Resolution R_{dpi} [dpi]	Maximum Output Frequency per channel F [kHz]					
0.5	1	2			3500	1750	1000	500	100	60
			Max. Movement Speed V_{max} [m/s]							
		x	500	50.8	>100	>100	>100	>100	>100	>100
	x	x	200	127	>100	>100	>100	>100	80	48
x	x	x	100	254	>100	>100	>100	>100	40	24
		x	80	317.5	>100	>100	>100	>100	32	19.2
x	x	x	62.5	406.4	>100	>100	>100	>100	25	15
x	x	x	50	508	>100	>100	>100	>100	20	12
x	x	x	25	1016	>100	>100	>100	50	10	6
x	x	x	20	1270	>100	>100	80	40	8	4.8
x	x	x	12.5	2032	>100	87.5	50	25	5	3
x	x	x	10	2540	>100	70	40	20	4	2.4
x	x	x	5	5080	70	35	20	10	2	1.2
x	x	x	4	6350	56	28	16	8	1.6	0.96
x	x	x	2.5	10160	35	17.5	10	5	1	0.6
x	x	x	2	12700	28	14	8	4	0.8	0.48
x	x	x	1	25400	14	7	4	2	0.4	0.24
x	x	x	0.5	50800	7	3.5	2	1	0.2	0.12
x	x	x	0.25	101600	3.5	1.75	1	0.5	0.1	0.06
x	x	x	0.125	203200	1.75	0.875	0.5	0.25	0.05	0.03
x	x	x	0.05	508000	0.7	0.35	0.2	0.1	0.02	0.012
x	x		0.02	1270000	0.28	0.14	0.08	0.04	0.008	0.0048

Table 1: Maximum output frequency and speed as a function of pole pitch and resolution

Definition:

Resolution R (Resolution is post quadrature)Pole pitch P (available 0.5; 1; 2 mm)Resolution factor Rf (Resolution factor available from 4 to 65536 in integer increments of one)Maximum Output Frequency per channel F (from 60 kHz to 3500 kHz)Max-Movement-Speed V_{max} Interpolation = $Rf/4$

$$R = P / Rf$$

Resolution [dpi] R_{dpi}

$$R_{dpi} = 25400 / R$$

 V_{max} is limited by following formulars:

$$1. V_{max} = 4 * F * R$$

$$2. V_{max} = P * 50 \text{ kHz}$$

Pin Assignment

Signal	Pin No.	
	C1 (FFC 180°)	C2 (FFC 90°)
A	1	1
/A	2	2
B	3	3
/B	4	4
Z	5	5
/Z	6	6
V-	7	7
V+	8	8

Dimensions

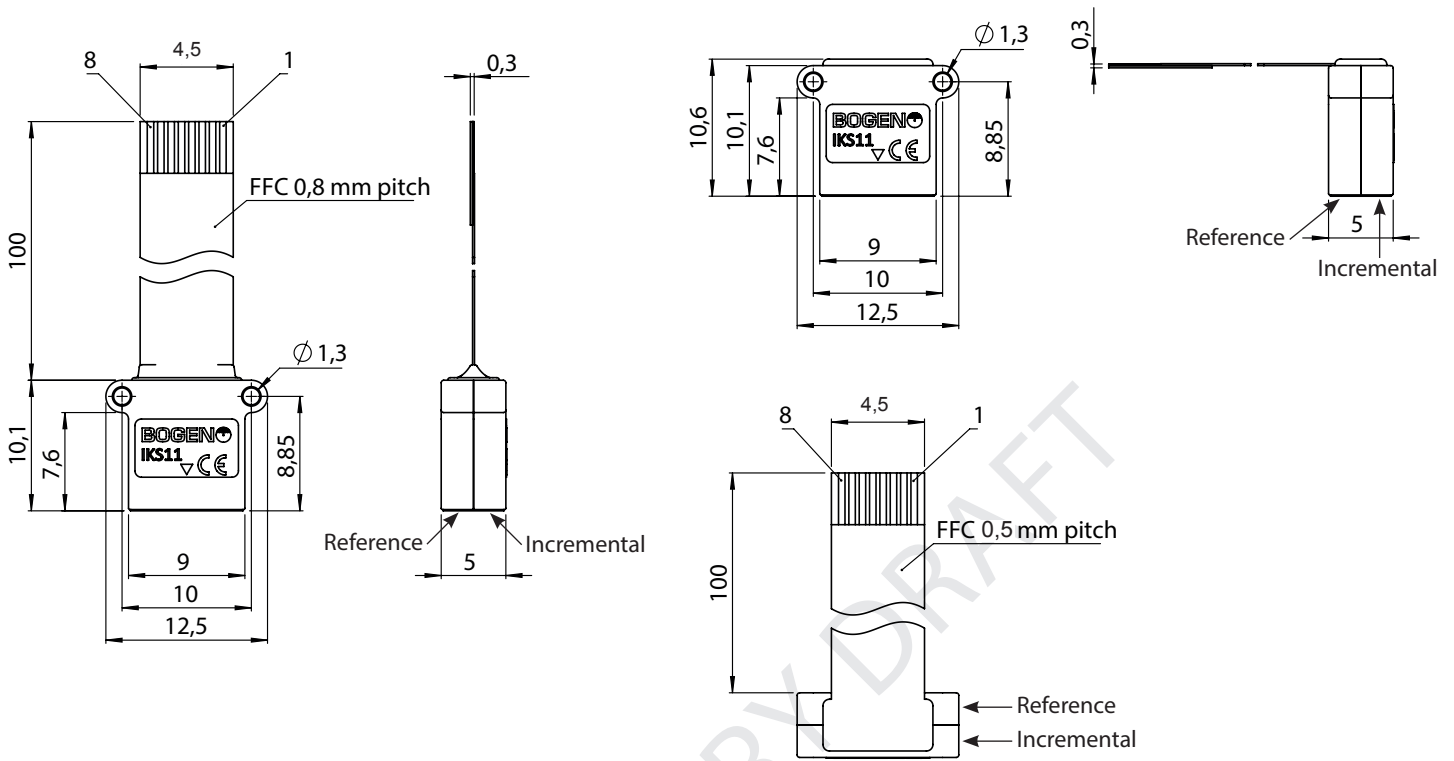

Optional Accessory – Order Codes for Linear Scales, 10 mm Width ⁽⁵⁾

Pole Pitch	Accuracy A3	Accuracy A10	Accuracy A20	Accuracy A40 (standard)
0.5	KBEE10-0.5-A3K	KBEE10-0.5-A10K	KBEE10-0.5-A20K	KBEE10-0.5-K
1	KBEE10-1-A3K	KBEE10-1-A10K	KBEE10-1-A20K	KBEE10-1-K
2	KBEE10-2-A3K	KBEE10-2-A10K	KBEE10-2-A20K	KBEE10-2-K

⁽⁵⁾ Scale dimensions: 10 mm x 1.3 mm (w/o cover tape), length up to 50 m. Other accuracies, other pole pitches, other scale widths and scales with reference track on request. See separate data sheet for linear scales for further possibilities.

Optional Accessory – Scales

Scales with different dimensions and number of poles are available. Please contact us.

Order Code

Parameters

 IKS11 -

Z	P	D	R	F	C
---	---	---	---	---	---

		Code ⁽⁷⁾	Explanation ⁽⁶⁾
Z	Reference Signal ^(7,8)	Z1. ...	Periodic index signal, from the pole pitch, length of index signal ... counts ⁽¹⁰⁾
		Z2. ...	From reference marks (requires 2-track magnetic tape with incremental track and reference track), length of index signal ... counts ⁽⁹⁾
		Z2.50	Periodic index signal, from the pole pitch with length of index signal 50 counts
P	Pole Pitch [mm]	P0.5	0.5 mm
		P1	1 mm
		P2	2 mm
D	Interface ⁽⁷⁾	D1	RS422
		D3	Push-Pull TTL
R	Resolution ⁽⁷⁾ [µm]	R0.25	Standard for pole pitch 0.5 mm
		R0.5	Standard for pole pitch 1 mm
		R1	Standard for pole pitch 2 mm
F	Maximum Output Frequency per channel ⁽⁷⁾ [kHz]	F1000	1000 kHz
		F ...	Other non-standard output frequencies, see section "Resolution and Speed" in table 1 on page 2.
C	Connector	C1	FFC 180°
		C2	FFC 90°
		C3	on request

⁽⁶⁾ standard parameters are bold

⁽⁷⁾ user programmable parameters (optional IKS-Programming device necessary)

⁽⁸⁾ if no index signal is needed, please do not connect pin "Z" an "/Z" on delivered connector

⁽⁹⁾ length of index signal available from 1 to 256

PRELIMINARY DRAFT